

Installation Manual

Table Bases

Z000000453

Revised 02 16 2015

Address 14400 Southcross Drive West
Burnsville, Minnesota 55306

Web Plymold.com
Phone 800.PLYMOLD

 **Plymold**
a division of Foldcraft

Unpacking Your Shipment

Unpack and identify each component in each box that you received. If your shipment is missing parts, or too many parts were shipped, please contact Plymold.

Components

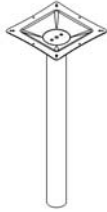

Metal Column with table plate

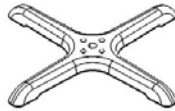

Metal Pedestal Base



#10x1.00" screw (8 each)



Table Base Glide



Table Shox - Optional

Tools Required



Screw Gun with #2 Phillips Bit



Screw Driver



Tape Measure



Pencil or Marker



3/4" Box End Wrench Set or Socket

Assembly Instructions

Step 1: Base Foot Assembly

- 1: Remove bolt from the bottom of the table column with the lock washer and flat washer.
- 2: Place the base on the table column and attach with flat washer, lock washer and bolt.
- 3: Securely tighten bolt using 3/4" box wrench or socket.



Step 2: Table Shox to Base Assembly

- 1: Screw the table shox into the holes on the bottom of the table base.
- 2: Tighten with flat blade screw driver.



Assembly Instructions

Step 3: Base to Table Assembly

- 1: Turn table top upside down on floor (protect table top with cardboard).
- 2: Locate center of table top and mark with an "X".
- 3: Align plate with "X" marked on the bottom of the table top.
- 4: With a screw gun, attach the complete base assembly to the table top with 8 - #10 x 1.00" screws. One in each of the 8 holes of the table plate.

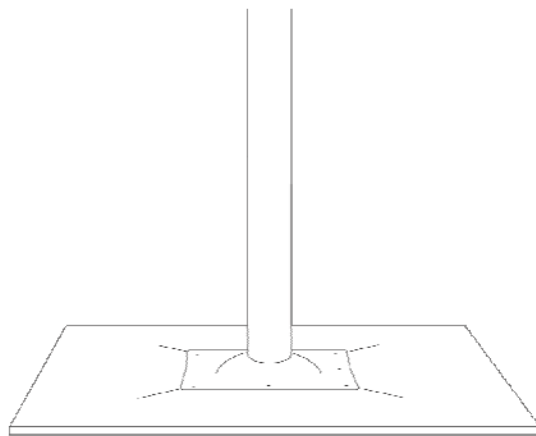

Step 4: Final Product

- 1: Turn table right side up..
- 2: Orientation of feet/legs of table base should point towards corners of the table for maximum stability.
- 3: Position table where you want it.
- 4: Clean table top and cover until ready to use.

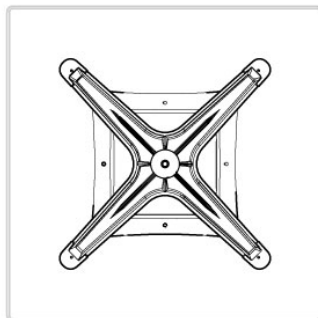

Shown Bottom up

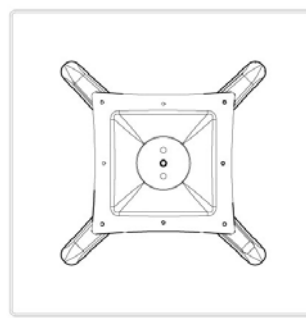

Shown Top Down