

Installation Manual

Contour

Island Style

Z000000003

Revised 12/14/16

Unpacking Your Shipment

Unpack and identify each component in each box that you received. If your shipment is missing parts, or too many parts were shipped, please contact Plymold.

Components

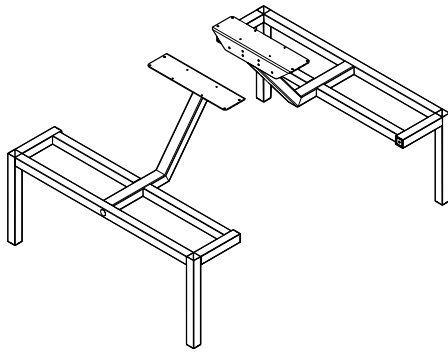

ISLAND STYLE FRAME

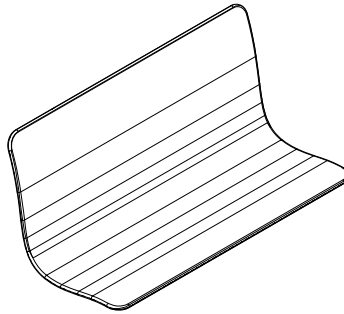

CONTOUR SEAT

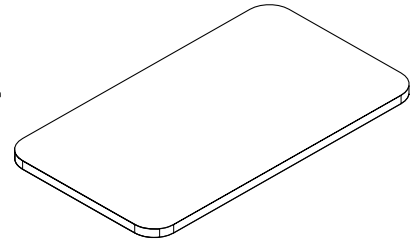
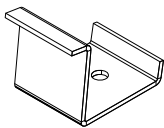
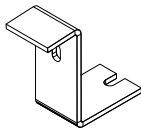

TABLE TOP

P85790 SINGLE SEAT HARDWARE KIT



REAR SEAT HOOK



FRONT SEAT HOOK

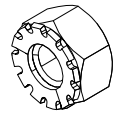

NUT 1/4-20

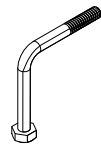

1/4-20 ELBOW BOLT

P85888 JUPITER FRAME HARDWARE KIT

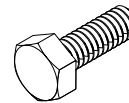

1/4-20 x 3/4" BOLT

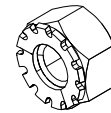

NUT 1/4-20

OTHER HARDWARE

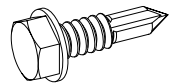

TEK SCREW #10 x 1"

P85889 JUPITER TABLE & FLOOR HARDWARE KIT

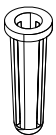

PLASTEC FLOOR ANCHOR

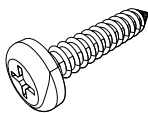

SCREW #10 X 1"

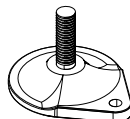

ADJUSTABLE PLASTIC GLIDE (A)

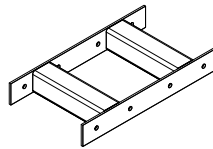

EXPANSION SPACER

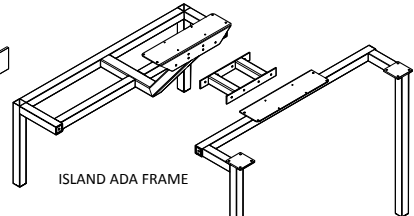

ISLAND ADA FRAME

Tools Required



SCREW GUN W/ #2 PHILLIPS BIT



PENCIL OR MARKER



SCREW DRIVER



5/16" & 7/16" SOCKET



RATCHET AND 7/16" OPEN END WRENCH



LEVEL



TAPE MEASURE



Assembly

Step 1: Glide Assembly - Island Style Frame

- a. Assemble a thread-in glide into the insert in each of the four (4) legs.

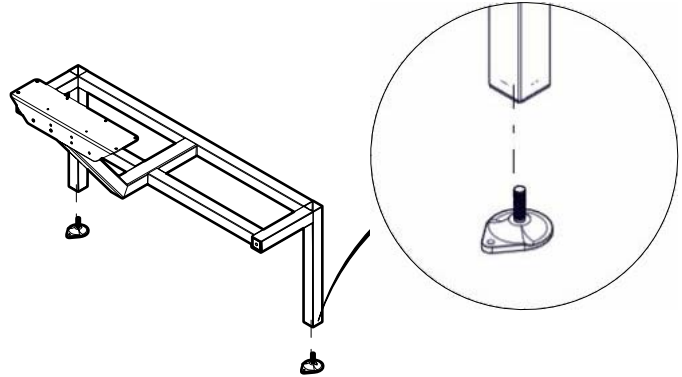

Step 2: Assemble Seat to Frame

- a. **Note: An expansion spacer is required for table tops wider than 24".**

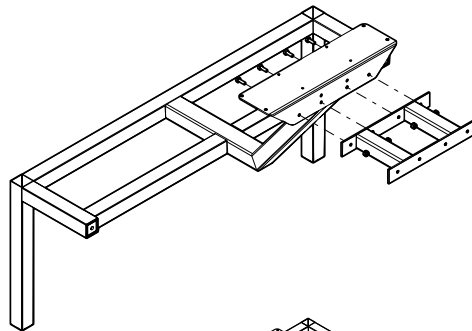

- b. Align the table angle holes.

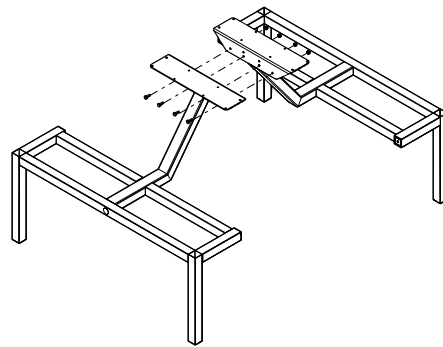

- c. Locate the Jupiter Frame Hardware Kit and fasten the two frame halves together using 1/4-20x3/4" bolts and nuts.

Note: Hand tighten nuts and bolts.

- d. Level table angles.

- e. Tighten nuts and bolts using a wrench.

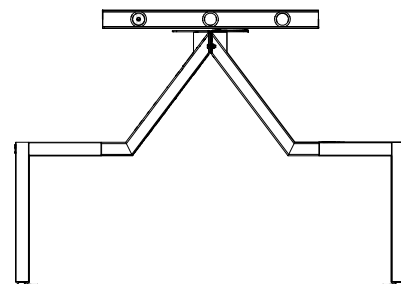

Assembly

Step 3: Assemble Seat to Frame

- a. Locate the Single Seat Hardware Kit.
- b. Position seat on end and insert front hooks.

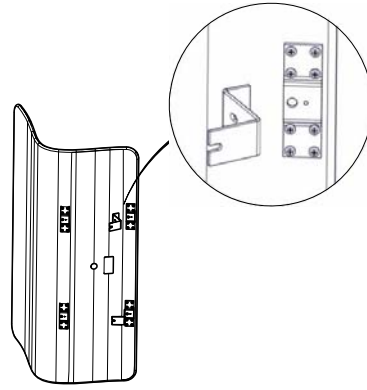

- c. Position the seat over the frame by tipping the edge of the seat forward and pulling the seat into place.

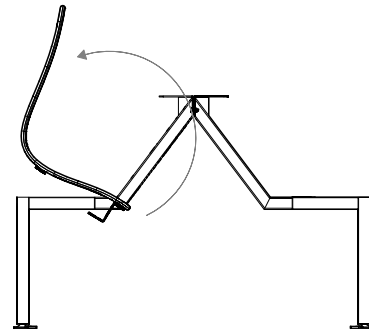

- d. Attach elbow bolts to front seat hooks and hand tighten 1/4-20 kep nut.

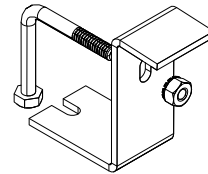

- e. Insert short tongue of rear seat hook into the seat plate. Using a flathead screwdriver pry rear seat hook until it pops into place.

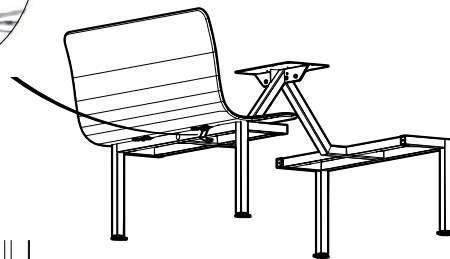
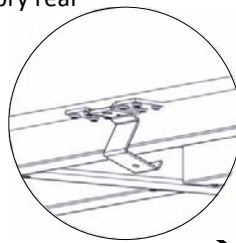
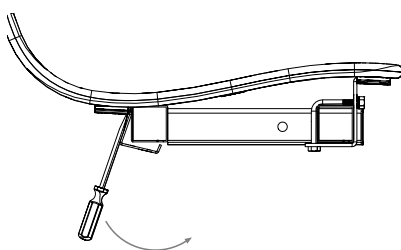

- f. Now that the seat is installed, insert a self-drilling screw into the hole in the rear seat hook. One screw for each rear seat hook. Do not over

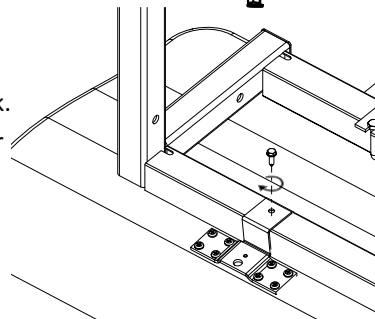

Assembly

Step 4: Installing Table Top

- a. Locate the Jupiter Table & Floor Hardware Kit.
- b. Place the table top on the frame.
- c. Position table per drawings below.
- d. Secure the table top from moving while fastening, using (16) #10 x 1.0" screws.

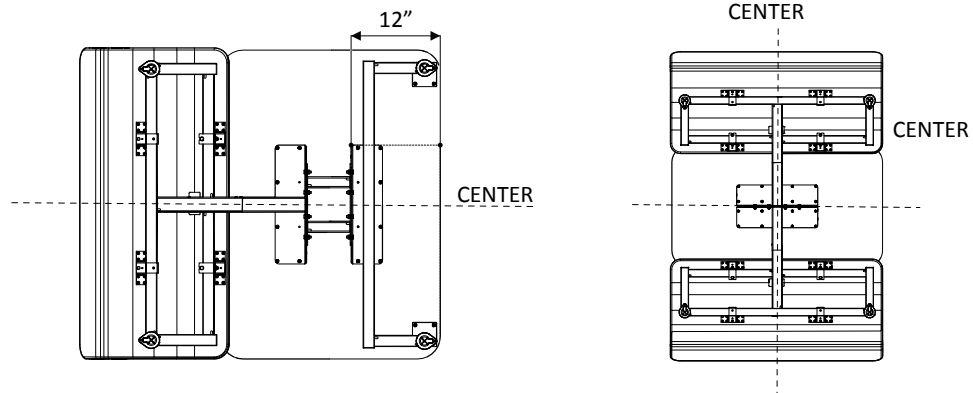

Step 5: Position and Level Booth

- a. Confirm location of booth/frames with the floor plan.
- b. Level booth by adjusting glides.

Assembly

Step 6: Fasten Glides to Floor

- a. Rotate glides to point the mounting hole towards the center of the booth.
- b. With a pencil, mark the hole location on the floor using the holes in the glide.
- c. Turn the glide away 90 degrees from its current position to expose the mark on the floor.
- d. Using a hammer drill and a 1/4" masonry bit, drill a 1 1/4" deep hole on the pencil mark.
- e. Place a plastic anchor in the hole and then rotate glide back so the hole lines up with the plastic anchor in the floor.
- f. Insert a #10 x 1.0" screw through the hole in the glide and secure into the plastic anchor.

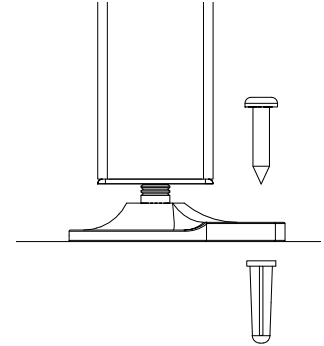

Note: Frames must be anchored to the floor to maintain stability and prevent personal injury.

Step 7: Care.

- a. Clean furniture and protect unit until ready for use.

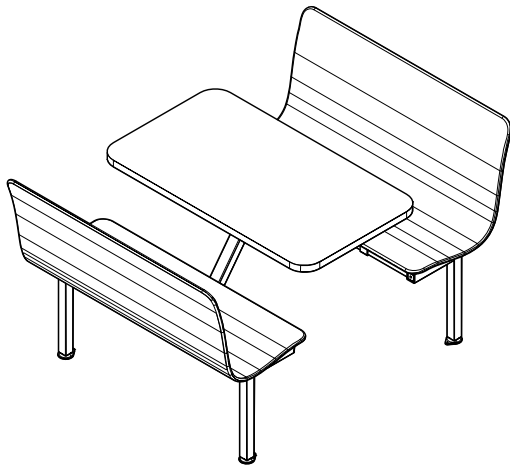

Island Style Frame Contour Booth

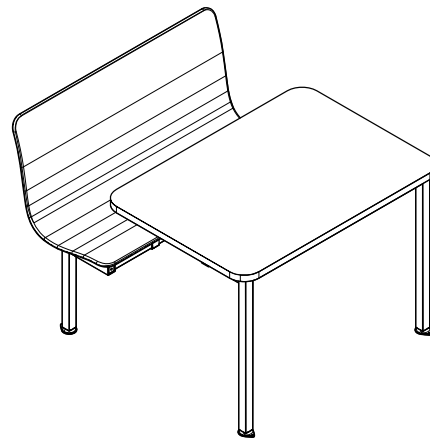

Handicap Accessible Island Style Frame