

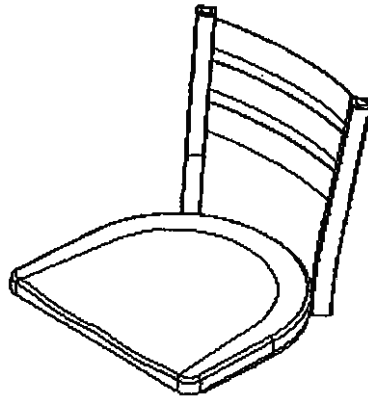

your source for furnishing solutions

INSTALLATION INSTRUCTION

PRODUCT: CHAIRHEAD ATTACHMENT
MANUAL: Z000000121



ATTENTION INSTALLERS: PLEASE PRESENT INSTALLATION DOCUMENTS TO FACILITIES MANAGER.

REVISION: A
DATE:1-31-06

COMPONENT INDEX FOR ASSEMBLY

UNPACKING YOUR SHIPMENT

Unpack and identify each component in each box that you received. If your shipment is missing parts, or too many parts were shipped, please contact Plymold Seating. Phone 507-789-5111

COMPONENTS:

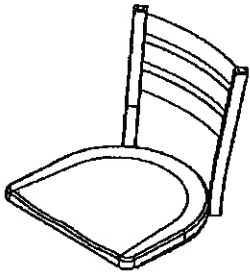

CHAIRHEAD



BUTTON CHAIRHEAD

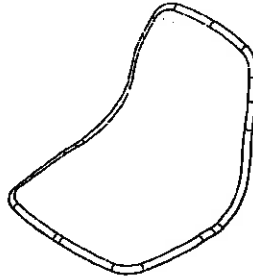

SHELL SEAT

TOOLS REQUIRED:

SCREW GUN W#2 PHILLIPS BIT
SCREW DRIVER
TAPE MEASURE
PENCIL OR MARKER
WRENCH SET



#10X1.00"



**1/4"-20 NYLOC
NUT**



WASHER

STEP 1: INSPECT CHAIRHEAD FOR SWIVEL MOUNT

1. These chairheads are provided with factory mounted swivel mechanisms.

6430	6120	6730	6100
6460	6130	6740	6200
6400	6760	6720	6210
6110	6710	6750	6710

2. Proceeds to Step #2.

Note: For other styles see instructions below.

STEP 2: MOUNTING FIXED PLATE ON BUTTON SEAT

1. Align the pre-drilled pilot holes on the bottom of the seat with the four slots on the swivel plate.

Note: The front of the mounting plate is stamped "FRONT TOP" and should be positioned to the front of the chairhead.

2. Using four (4) #10 x 1.00" wood screws and washers to fasten the swivel to the seat bottom.

3. Firmly tighten all screws.

4. Proceed to STEP 4.

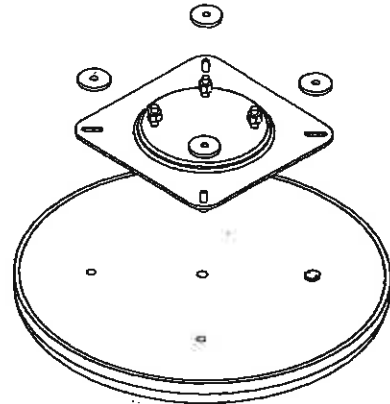

STEP 3: MOUNTING FIXED PLATE OR SWIVEL TO SHELL SEAT

1. Align the threaded stud on the bottom of the seat with the four slots on the swivel plate.

Note: The front of the mounting plate is stamped "FRONT TOP" and should be positioned to the front of the chairhead.

2. Using four (4) 1/4"-20 nuts fasten the swivel to the seat bottom.

3. Firmly tighten all nuts.

4. Proceed to STEP 4.

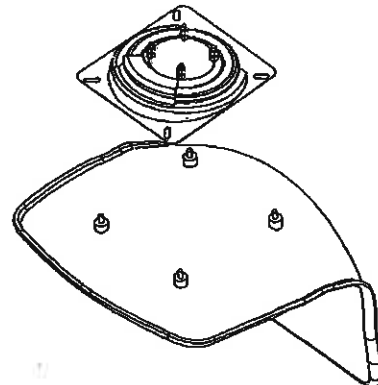

STEP 4: MOUNTING CHAIRHEAD TO FRAME

1. Align the studs on the base of the swivel to the holes on the seat post.

2. Place a 1/4"-20 nut over each stud and firmly tighten with 7/16" wrench.

Note: Orientate the front edge of the chairhead with adjacent table edge.

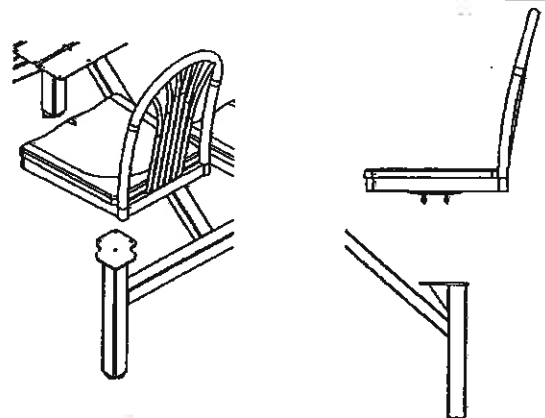

STEP 5: CARE

1. Clean furniture and protect unit ready for use.

CARE & CLEANING:

Day to day soil

Remove ordinary dirt and smudges with a mild soap and warm water solution. Rinse with a water dampened cloth. Dry with a soft cloth or towel.

Heavy soiling

Soiling can be removed with the following non-abrasive household cleaners and soft cloth.

Formula 409 All-Purpose Spray Cleaner

Fantastik Spray Cleaner

Other similar household cleaners

Rinse cleaned area with water dampened cloth. Dry with a clean cloth or towel.

For more difficult stains

Dampen soft white cloth with a solution of (10%) household bleach and (90%) water. Rub gently. Rinse with water dampened cloth to remove bleach concentration.

Please Review Carefully

Should you desire to use other cleaning methods carefully try them in an inconspicuous area to determine potential damage to the material. Never use harsh solvents or cleaners which are intended for industrial applications. To clean stained or soiled areas, a soft white cloth is recommended. Avoid use of paper towels.

PRODUCT WARRANTY

Plymold warrants all products manufactured and/or marketed by Plymold to be free from defects in material and workmanship under normal usage and service for one (1) year from date of purchase unless extended warranties have been established for specific products. The customer assumes responsibility for normal wear and tear.

This Warranty Agreement excludes all products or component parts that, in the opinion of Plymold, have been subjected to negligent use, misuse, alteration, accident or improper installation. Plymold reserves the right to make design changes, improve design or change specifications at any time without any contingent obligation to owners of products previously sold.

Plymold shall not be held responsible by customer or potential customers for failure to perform any of the obligations of this Warranty Agreement if such failures are the result of circumstances of Force Majeure such as, but not limited to floods, earthquakes, transportation strikes, labor disputes with any outside suppliers, or any other conditions beyond the control of Plymold.



615 Centennial Drive Kenyon, MN 55946
Phone 507-789-5111, 800-PLYMOLD (759-6653) Fax: 507-789-8315
Email: seating@plymold.com www.plymold.com