

Installation Manual

KD Wall Style Adjustable

Z000000385

Released 11/30/16

Assembly

Step 1: Glide Assembly - Adjustable Wall Style Frame

- a. Assemble a thread-in glide into the insert in each of the four (4) legs.

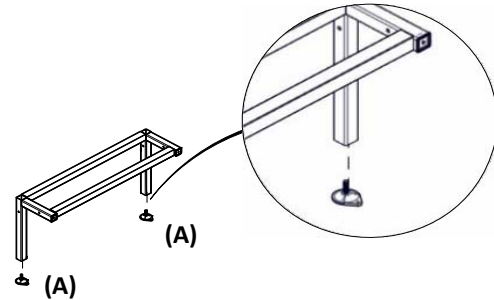

Step 2: Frame Assembly

- a. Using 3/8"-16 x 3 3/4" hex head cap screw, 3/8-16 lock nut and 3/8" washers, assemble the seat support leg to the main support frame.

Note: Start with the Center holes and if needed can open or close the booth opening if needed.

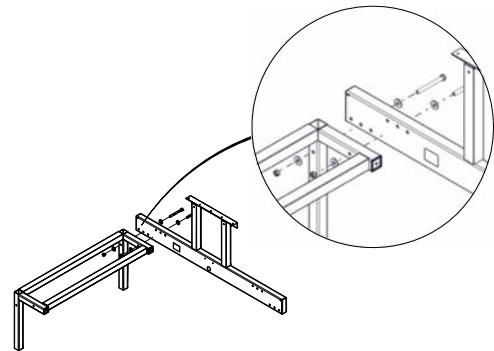

- b. Repeat step a with the second seat support leg.

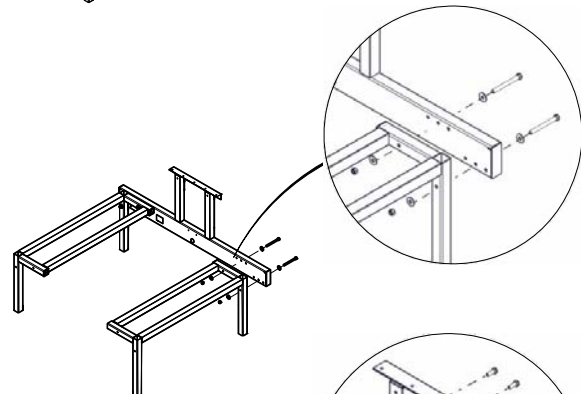

- c. Attach the cantilever to the main support frame using 1/4-20 x 5/8" machine screws on the bottom. Use the 1/4-20 x 3/4" hex head cap screws with a 1/4-20 kep nut on the top.

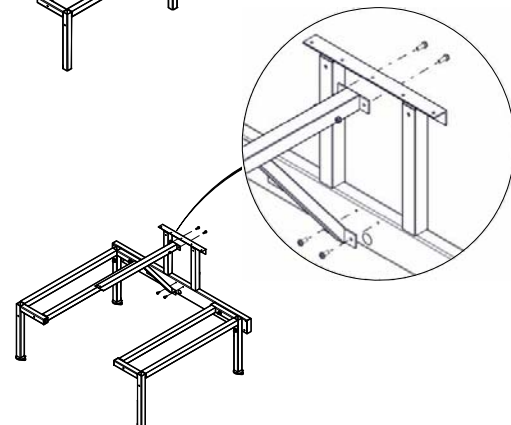

Step 3: Fasten Glides to the Floor

- a. Rotate glides so that the mounting hole is pointing towards the center of the booth.
- b. With a pencil, mark the hole location on the floor using the holes in the glide.
- c. Turn the glide away 90 degrees from its current position to expose the mark on the floor.
- d. Using a hammer drill and a 1/4" masonry bit, drill a 1 1/4" deep hole on the pencil mark.
- e. Place a plastic anchor in the hole and then rotate glide back so its hole lines up with the plastic anchor in the floor.

