

Installation Manual

# Dining Counter Powered

Z000000469

Revised 07/03/18

Address 14400 Southcross Drive West  
Burnsville, Minnesota 55306

Web [Plymold.com](http://Plymold.com)  
Phone 800.PLYMOLD

 **Plymold**  
a division of Foldcraft

# Unpacking Your Shipment

Unpack and identify each component in each box that you received.

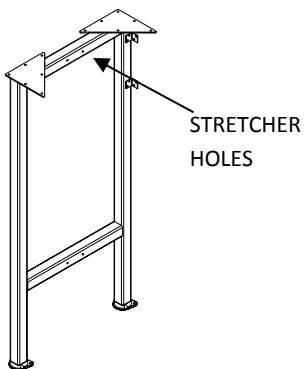

LEFT AND RIGHT END LEGS (STETCHER HOLES 1 FACE)  
CENTER LEGS (STETCHER HOLES 2 FACE)

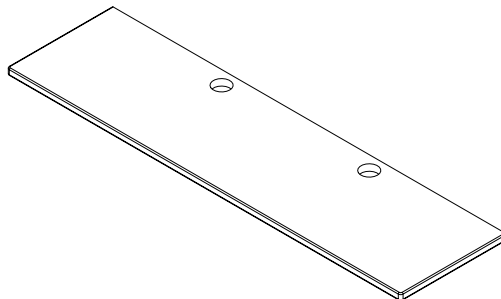

COUNTER TOP LENGTH VAR-  
IES. HOLES FOR POWER ARE  
OPTIONAL

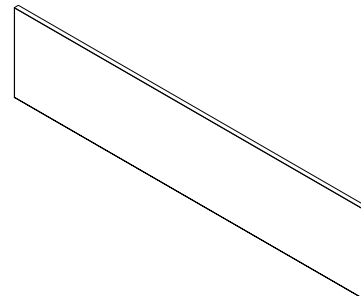

SKIRT, LENGTH VARIES

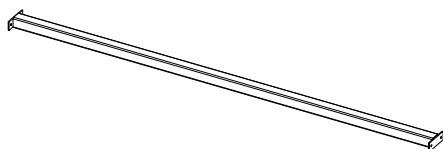

LEG STRETCHER

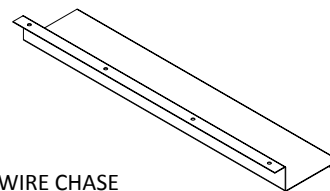

WIRE CHASE

## HARDWARE

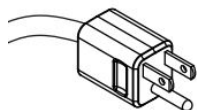

POWER (STARTER) CABLE

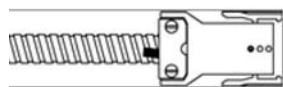

CONNECTOR (JUMBER ) CABLE

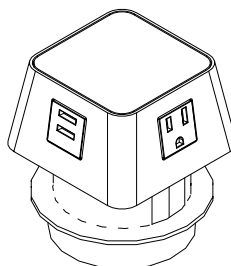

MOIRE RECEPTACLE

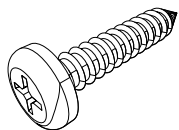

#10x1" Pan Head  
Screw

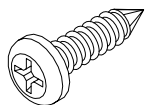

#10 x .5625" Pan  
Head Screw

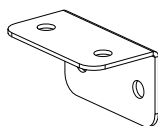

Angle Bracket  
1" x 1" x2"

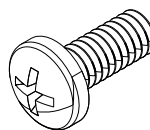

MACHINE SCREW  
1/4-20 x 5/8"



1" Plastic Anchor

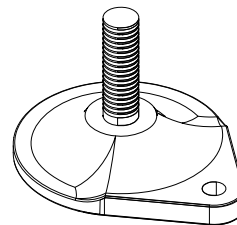

Teardrop Glide

# Assembly

## Step 1: Glide Assembly

- a. Assemble thread-in glide into the insert, in each set of legs

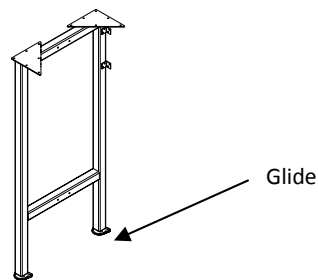

## Step 2: Attach Legs to Stretchers

- a. Using 1/4-20 x 5/8" Machine Screws fasten legs together. End legs are made to accept a stretcher on 1 face. Center legs are made to accept a stretcher on 2 faces.

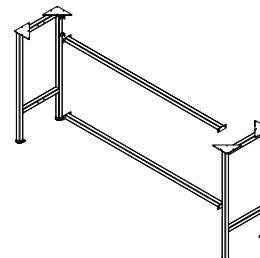

## Step 3: Attach Top

- a. Center top from left to right on leg and stretcher assembly. Top should be flush with the back of legs.
- b. Then using #10 x 1 screws attach the frame to the underside of the top, through the triangle plates on the legs.

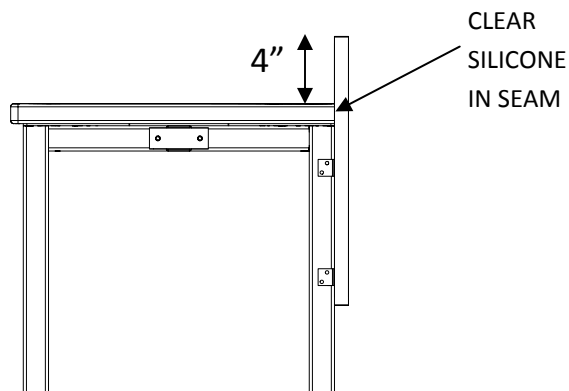
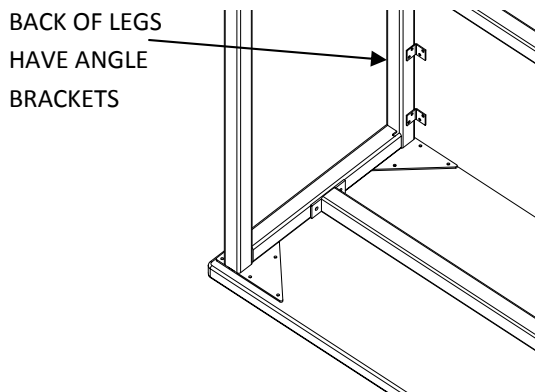

## Step 4: Attach Skirt

- a. Center skirt flush to the ends of the top. The skirt should sit 4" above the top. Using #10 x 0.625" screws attach the skirt to the legs through the angle brackets on the legs. (We recommend using clear silicone to seal the seam between the top and the skirt.)
- b. Add 1"x1"x2" angle brackets to finish attaching skirt. Use 10 x .5625" Pan Head Screws. Space evenly across length of skirt

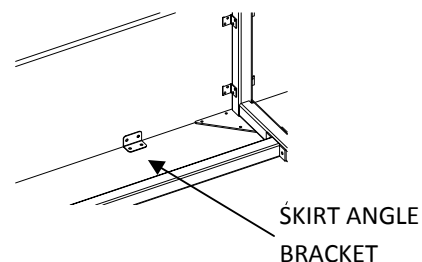

**Step 5: Add Power/ USB (OPTIONAL)**

- a. Start with Link 1 on the end of the counter, nearest your power source.
- b. Slide the cords through the opening . Secure power in place using images on the right as a guide.
- c. Repeat step b. with your remaining links .
- d. From below the top secure your wire chases to the underside of the top and the front face of the skirt using #10 x 0.5625" pan head screws.  
Hide all cords up inside the wire chase box.

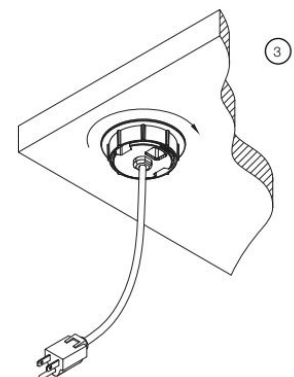
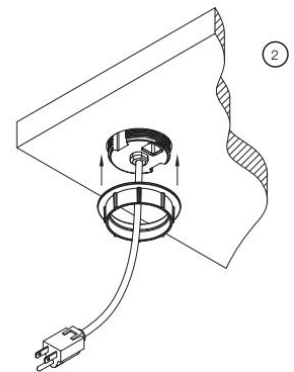
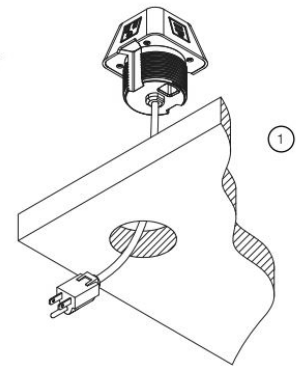
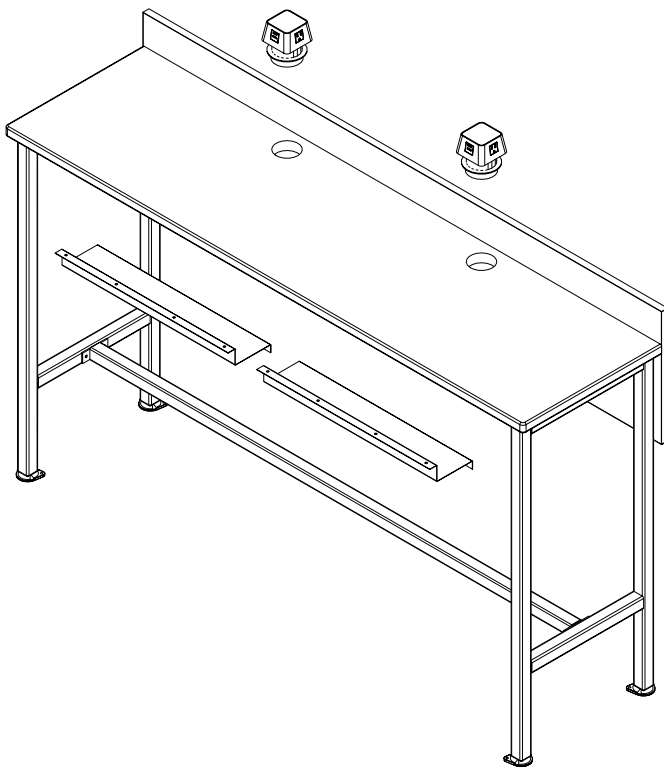

## Step 6: Fasten Glides to Floor

- a. Rotate glides to point the mounting hole towards the center of the counter.
- b. With a pencil, mark the hole location on the floor using the holes in the glide.
- c. Turn the glide away 90 degrees from its current position to expose the mark on the floor.
- d. Using a hammer drill and a 1/4" masonry bit, drill a 1 1/4" deep hole on the pencil mark.
- e. Place a plastic anchor in the hole and then rotate glide back so the hole lines up with the plastic anchor in the floor.
- f. Insert a #10 x 1.0" screw through the hole in the glide and secure into the plastic anchor.

**Note: Frames must be anchored to the floor to maintain stability and prevent personal injury.**

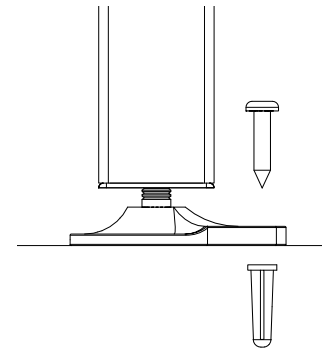

## Step 7: Clean

- a. Clean and protect top until ready for use.

