

Installation Manual

Take-Out Order Shelf

Z000000608

Released 07/06/21

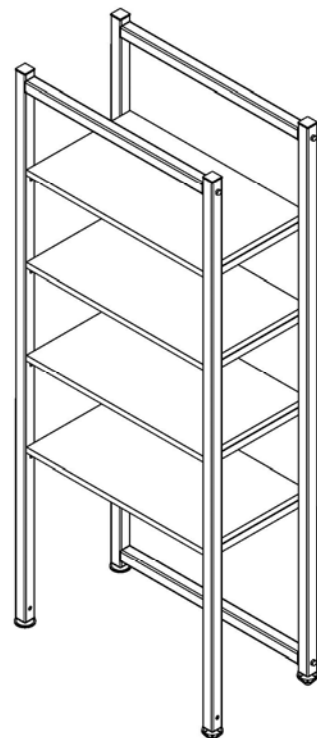

Address 14400 Southcross Drive West
Burnsville, Minnesota 55306

Web Plymold.com
Phone 800.PLYMOLD

 **Plymold**
a division of Foldcraft

Components

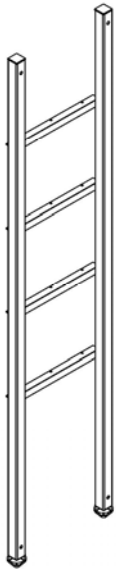

Frame—Ladder Ends

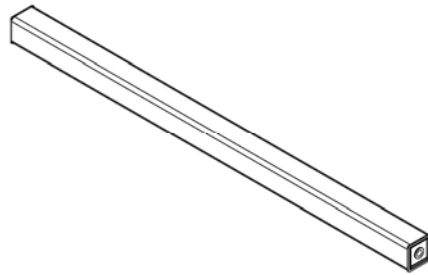

Stretcher with,
(2x) 3/8-16 x 2.5" L
Hex Head Cap Screw

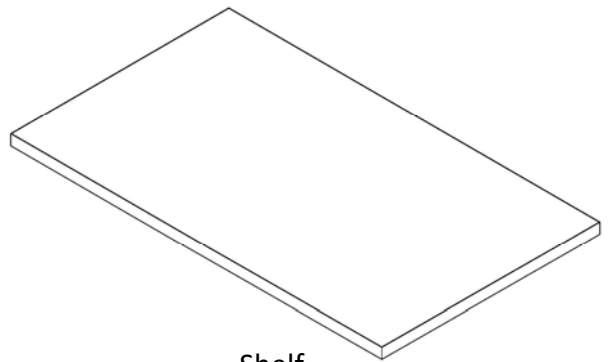
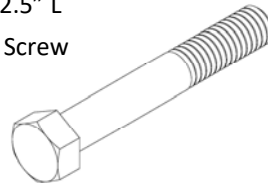

Shelf

P85996 TITAN FLOOR FASTENING

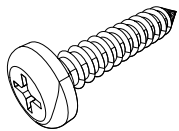

#10x1" Phillips Pan
head Screw



PLASTIC FLOOR
ANCHOR

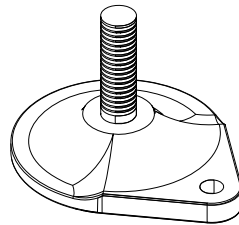

Teardrop Glide

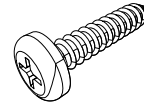

#8 x 0.625" Phillips
Pan Head

Assembly

Step 1: Glide Assembly -

- a. Assemble a thread-in glide into the insert in each of the four (4) legs.

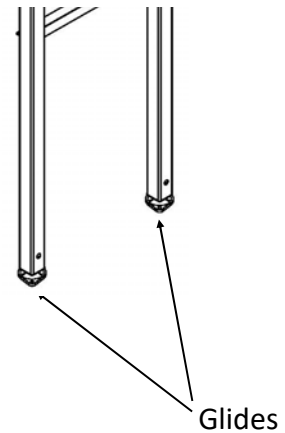

Assembly

Step 2: Assemble Frames

- You should have 2 ladder frame ends and 3 stretchers. The stretchers will have the 3/8-16 x 2.5" Hex Head Cap Screw threaded into them. Remove the hex head cap screws and use them to assemble the frame.
- Attach the stretchers to the ladder frames. You should have 2 at the top and 1 at the bottom back.

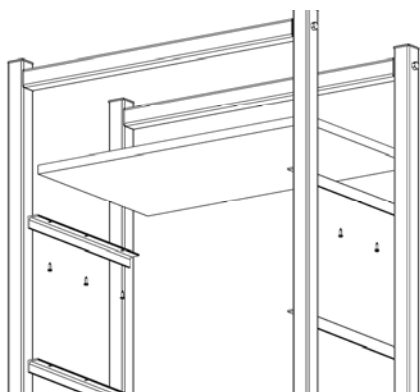

Big gap to angles
at the bottom

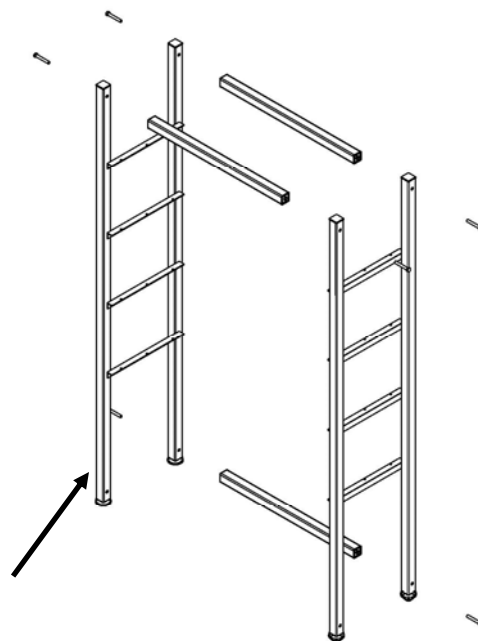

Step 3: Add Shelves

- Slide the top shelf into place. It should be flush at the front and back and have a slight gap on the ends. Using (6) #8 x 0.625" Phillips pan head screws fasten the shelf into place. Repeat this for the other 3 shelves, working your way from the top down to the bottom.

Step 4: Fasten Glides to the Floor

- Rotate glides so that the mounting hole is pointing towards the center of the unit.
- With a pencil, mark the hole location on the floor using the holes in the glide.
- Turn the glide away 90 degrees from its current position to expose the mark on the floor.
- Using a hammer drill and a 1/4" masonry bit, drill a 1 1/4" deep hole on the pencil mark.
- Place a plastic anchor in the hole and then rotate glide back so its hole lines up with the plastic anchor in the floor.
- Insert a #10 x 1.00" screw through the hole in the glide and secure into the plastic anchor.

Note: Take-Out Order Shelving must be anchored to the floor to maintain stability and prevent personal injury.

